

DATA LINK CONNECTOR

U

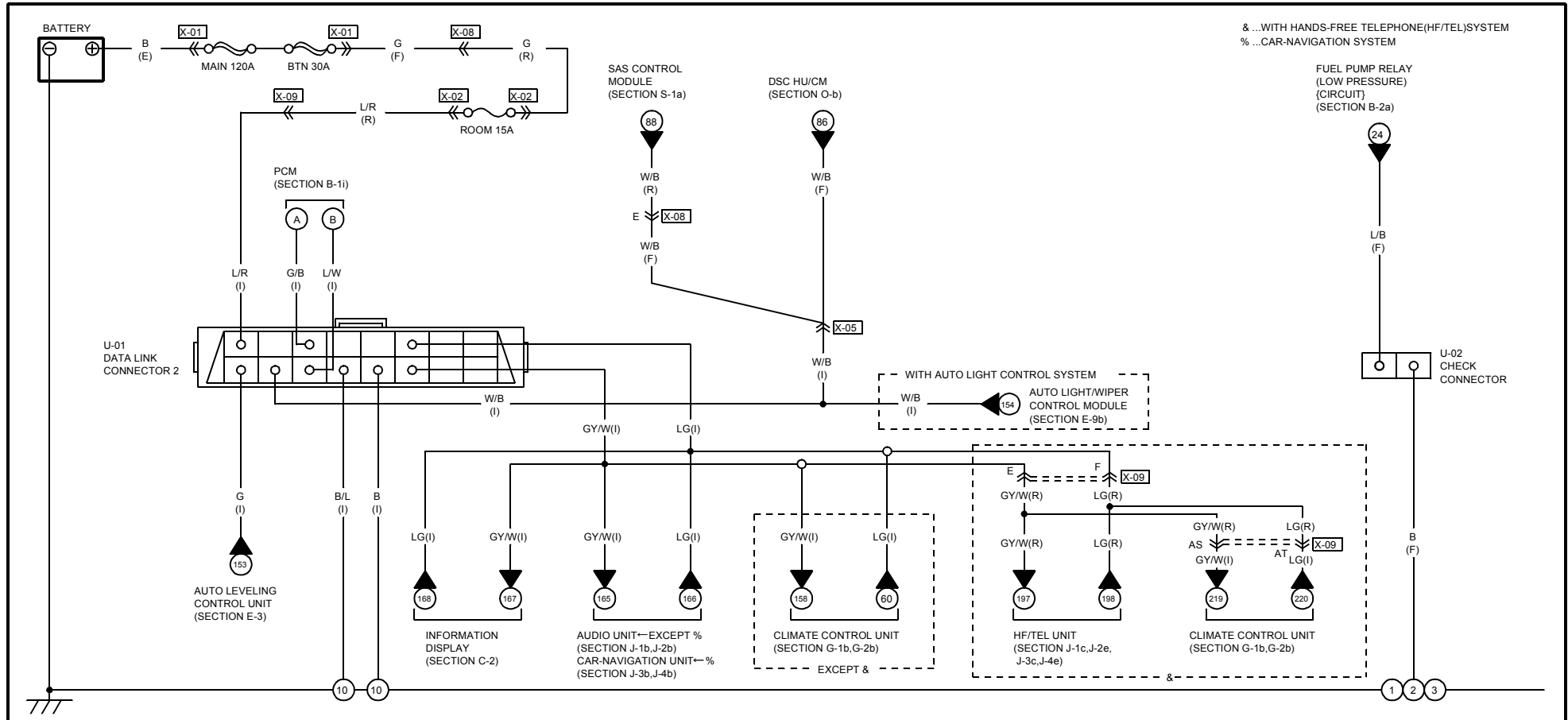

186

<p>U-01 DATA LINK CONNECTOR 2(I)</p> <p>NOTE: THIS IS THE CONNECTOR AS SEEN FROM THE TERMINAL SIDE.</p>	<p>U-02 CHECK CONNECTOR(F)</p> <p>NOTE: THIS IS THE CONNECTOR AS SEEN FROM THE TERMINAL SIDE.</p>			
---	---	--	--	--

HARNESS SYMBOL:  (F)  (E)  (R)

